

TUBO GAS SENZA SALDATURA

NERO | ZINCATO

D.N. mm	DIAMETRI		ESTERNO mm	SPESSORE mm	V.M. kg/m	LISCIO kg/m
	Ø pollici					
6		1/8"	10,2	1,80	0,372	0,369
8		1/4"	13,5	2,00	0,577	0,573
10		3/8"	17,2	2,00	0,753	0,747
15		1/2"	21,3	2,35	1,11	1,10
20		3/4"	26,9	2,35	1,42	1,41
25	▲	1"	33,7	2,90	2,23	2,21
32	▲	1" 1/4"	42,4	2,90	2,87	2,84
40	▲	1" 1/2"	48,3	2,90	3,30	3,26
50	▲	2"	60,3	3,25	4,63	4,56
70	▲	2" 1/2"	76,1	3,25	5,93	5,81
80	▲	3"	88,9	3,65	7,82	7,65
100	▲	4"	114,3	4,05	11,30	11,00
125		5"	139,7	4,85	16,70	16,20
150		6"	165,1	4,85	19,80	19,20

TUBO GAS SALDATO

ZINCATO SERIE LEGGERA

D.N. mm	DIAMETRI		ESTERNO mm	SPESSORE mm	ZINCATO V.M. kg/m	NERO LISCIO kg/m
	Ø pollici					
10		3/8"	17,2	2	0,80	0,74
15		1/2"	21,3	2,3	1,18	1,08
20		3/4"	26,9	2,3	1,47	1,39
25		1"	33,7	2,9	2,30	2,20
32		1 1/4"	42,4	2,9	2,95	2,82
40		1 1/2"	48,3	2,9	3,39	3,24
50		2"	60,3	3,2	4,70	4,49
70		2 1/2"	76,1	3,2	6,03	5,73
80		3"	88,9	3,6	7,93	7,55

▲ Anche preverniciato RAL 3000

TUBO S.S. LISCIO COMMERCIALE

BOLLITORE

DIAMETRO ESTERNO mm	SPESSORE mm	PESO kg/m
26,9	2,0	1,24
30	2,3	1,59
33,7	2,3	1,79
38	2,6	2,29
42,4	2,6	2,57
44,5	2,6	2,70
48,3	2,6	2,95
54	2,6	3,32
57	2,9	3,90
60,3	2,9	4,14
70	2,9	4,83
76,1	2,9	5,28
88,9	3,2	6,81
101,6	3,6	8,76
108	3,6	9,33

DIAMETRO ESTERNO mm	SPESSORE mm	PESO kg/m
114,3	3,6	9,9
133	4,0	12,8
139,7	4,0	13,5
159	4,5	17,1
168,3	4,5	18,1
193,7	5,4	25
219,1	6,3	31
244,5	6,3	37,1
273	6,3	41,6
323,9	7,1	55,6
355,6	8,0	68,3
368	8,0	70,8
406,4	8,8	85,9
419	8,8	88,7

TUBO NERO SALDATO SCORDONATO

DIAMETRO ESTERNO mm	SPESSORE mm	PESO kg/m
21,3	3,2	1,42
26,9	3,2	1,71
33,7	2,9	2,20
42,4	2,9	2,82

DIAMETRO ESTERNO mm	SPESSORE mm	PESO kg/m
48,3	2,9	3,24
48,3	3,2	3,55
60,3	3,2	4,50
76,1	3,2	5,75

TUBO DI GROSSO SPESSORE GSN

PER APPLICAZIONI MECCANICHE

DIAMETRO ESTERNO mm	SPESSORE mm					
	8	10	12,5	14,2	16	17,5
	PESO kg					
48,3	7,93	9,45				
51,0	8,43	10,1	11,9			
54,0	9,04	10,9	12,9			
57,0	9,65	11,6	13,8			
60,3	10,3	12,4	14,8			
63,5	10,9	13,2	15,8			
70,0	12,2	14,8	17,8	19,6	21,2	
76,1	13,4	16,3	19,7	21,7	23,7	
82,5	14,6	17,9	21,7	24,0	26,2	28,0
88,9	15,9	19,5	23,7	26,2	28,7	30,8
101,6	18,4	22,6	27,6	30,7	33,7	36,2
108,0	19,6	24,2	29,6	32,9	36,2	39,0
114,3	20,9	25,7	31,6	35,1	38,6	41,7
127,0	23,4	28,9	35,5	39,6	43,6	47,2
133,0	24,6	30,3	37,4	41,8	46,1	49,9
139,7	25,9	32,0	39,5	44,0	48,6	52,7
152,4	28,4	35,1	43,4	48,5	53,6	58,1
159,0	29,6	36,7	45,4	50,8	56,2	60,9
168,3	31,5	39,0	48,4	54,1	59,9	65,0
177,8	33,4	41,4	51,3	57,4	63,6	69,1
193,7	36,5	45,3	56,2	63,0	69,8	75,9
219,1	41,5	51,6	64,1	71,9	79,8	86,9
244,5			72,0	80,8	89,8	97,8
273,0			80,9	90,9	101	110
298,5			88,8	99,8	111	121
323,9			96,7	109	121	132
355,6			107	120	133	146
368,0			110	124	138	151
406,4			122	138	153	168
419,0			126	142	158	173

TUBO SALDATO CARPENTERIA

NERO | ZINCATO A CALDO

DIAMETRO pollici	DIAMETRO mm	SPESSORE mm	PESO NERI kg/m	PESO ZINCATI kg/m
3/8	16,75	2,0	0,74	0,81
1/2	21,25	2,3	0,95	1,18
3/4	26,75	2,5	1,41	1,51
1	33,48	2,5	2,01	2,12
1 1/4	42,25	3,0	2,58	2,71
1 1/2	48,25	3,0	3,37	3,32
2	60,00	3,0	4,22	4,28
2 1/2	76,00	3,0	5,40	6,04
3	88,90	3,0	6,36	7,14
3 1/2	101,60	3,0	7,32	9,10
4	114,30	3,0	8,21	10,30

TUBO SALDATO

RICAVATTO DA NASTRO A FREDDO

DIAMETRO mm	SPESSORE mm			
	1	1,2	1,5	2
	PESO kg			
8	0,17			
10	0,22	0,26	0,32	
12	0,27	0,32	0,39	
14	0,32	0,38	0,46	0,54
16	0,37	0,44	0,54	0,69
18	0,42	0,50	0,61	0,79
20	0,47	0,55	0,68	0,88
22	0,52	0,61	0,76	0,98
25	0,59	0,70	0,86	1,13
28	0,67	0,79	0,98	1,28
30	0,71	0,85	1,05	1,38

TUBO TONDO SALDATO

NERO | DECAPATO | ZINCATO

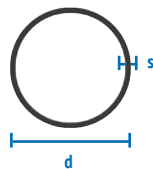

DIAMETRO mm	SPESSORE mm					
	1,5	2	3	4	5	6
	PESO kg					
15	0,50	0,59				
16	0,54	■ 0,73				
18	0,61	■ 0,79				
20	0,68	■ 0,89				
22	0,76	■ 0,99				
25	0,87	■ 1,13	1,62			
27	0,93	1,22	1,76			
28	0,98	■ 1,28	1,85			
30	1,05	■ 1,38	2,00			
32	1,13	■ 1,48	2,15			
33	1,18	1,55	2,25	2,86		
35	1,24	■ 1,63	2,37			
38	1,41	1,87	2,59	3,38		
40	1,42	■ 1,88	2,74	3,55		
42	1,50	1,97	2,89	3,75		
45	1,61	■ 2,12	3,11	4,05		
48	1,72	■ 2,27	3,33	4,38	5,30	
50	1,79	■ 2,37	3,48	4,54	5,55	
54		2,44	3,78			
55		2,61	3,85			
57	2,05	2,71	4,00	5,23		
60	2,16	2,86	4,22	5,52	6,78	
63			4,40	5,70		
65	2,35	3,11	4,59	6,02		
70	2,53	3,35	4,96	6,51	8,02	
76	2,76	3,65	5,40	7,10	8,76	
80	2,90	3,85	5,70	7,50	9,26	
89	3,23	4,29	6,39	8,38	10,38	12,17

■ Anche decapato

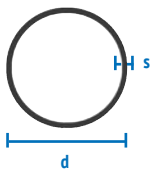

TUBO TONDO SALDATO

NERO | DECAPATO | ZINCATO

DIAMETRO mm	SPESSORE mm						
	2	3	4	5	6	8	10
	PESO kg						
102	4,93	7,32	9,67	11,96	14,37	18,56	21,82
108	5,23	7,77	10,26	12,70	15,09	19,06	24,20
114	5,52	8,21	10,85	13,44	15,99	20,93	25,70
121	5,87	8,73	11,54	14,31	17,02	21,03	27,40
127	6,16	9,17	12,13	15,04	17,90	23,50	28,90
133	6,46	9,62	12,73	15,78	18,79	24,68	30,30
139,7		10,11	13,39	16,61	19,78	26,00	32,00
152		11,02	14,60	18,13	21,60	28,44	35,12
159		11,54	15,29	18,99	22,64	29,82	36,75
168		12,21	16,18	20,10	23,97	31,57	39,04
177,8		12,94	17,16	21,33	25,45	33,54	41,40
193,7		13,98	18,55	23,06	27,52	36,30	45,30
219		15,98	21,21	26,39	31,06	41,61	51,57
244,5			23,75	29,57	35,33	46,71	57,90
273		20,63	26,54	33,05	39,55	52,34	64,94
323			31,56	39,92	46,30	62,32	77,41
339,7			33,15	41,32	49,44	65,52	81,41
355,6			34,72	43,28	51,79	68,66	85,33
406,4			39,74	49,55	53,32	78,70	97,88

TUBO TONDO SALDATO

SERIE SPECIALE

DIAMETRO mm	SPESSORE mm		
	1,5	2	3
	PESO kg		
100	3,67	4,90	7,35
120	4,41	5,88	8,82
150	5,51	7,35	11,02
180	6,61	8,82	13,23
200	7,35	9,80	14,70
220	8,08	10,78	16,16
250	9,08	12,90	18,15
300	11,0	15,20	21,78

TUBOLARE QUADRO

NERO | DECAPATO | ZINCATO

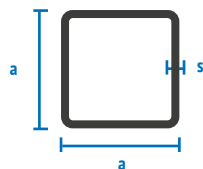

DIMENSIONI a mm	SPESSORE mm								
	1,5	2	3	4	5	6	8	10	12
	PESO kg								
10	0,34								
12	0,43								
15	0,57	0,70							
20	• 0,81	1,02	1,36						
25	• 1,05	1,34	1,89	2,64	3,14				
30	• 1,28	• 1,65	2,36	2,94	3,93	4,52			
35	1,52	1,96	2,77	3,46					
40	• 1,75	• 2,28	3,30	4,80	5,33	6,41			
45	1,99	2,60	3,71	4,72	5,61				
50	• 2,20	• 2,78	4,21	5,58	6,56	7,56	10,20	12,60	
55			4,52						
60	• 2,69	• 3,54	5,19	6,71	7,97	10,15	13,06	15,70	
70	3,00	4,16	6,13	7,97	9,54	11,10	15,57	18,80	21,90
80		• 4,79	7,07	9,22	11,11	12,99	16,36	22,00	25,60
90		5,42	8,01	10,48	12,68	15,80	20,60	25,10	29,40
100		• 6,07	8,96	11,73	14,24	17,70	21,40	25,60	25,60
110			9,90	12,99	15,83	19,60	23,90	28,70	33,00
120			10,84	14,25	17,40	21,50	28,10	34,60	40,70
130			12,00	15,82	19,62	23,36	30,60	37,70	44,50
140			12,72	17,19	21,36	25,49	33,59	40,80	48,20
150			13,62	18,01	22,11	27,10	35,70	44,00	53,24
160			14,61	19,40	23,76	29,00	38,20	47,10	55,80
175			15,98	21,07	26,04	31,90	42,00	51,80	
180			16,70	21,78	26,85	32,80	43,20	53,40	63,30
200			18,60	24,29	29,94	36,60	48,30	59,70	70,90
220				26,81	33,12	40,30	53,30	66,00	78,40
250				30,57	37,79	45,10	60,80	75,40	89,70

• Anche zincato

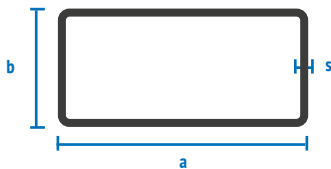

TUBOLARE RETTANGOLARE

NERO | DECAPATO | ZINCATO

DIMENSIONI		SPESSORE mm						
a	b	1,5	2	2,5	3	4	5	6
mm		PESO kg						
15	10	0,52						
20	10	• 0,64	0,81					
20	15	0,75	0,97					
25	10	0,75	0,97					
25	15	0,87	1,13					
30	10	0,87	1,13					
30	15	• 0,99	1,29	1,44	1,65			
30	20	1,11	1,44	1,77	2,07			
30	25	1,22	1,60	1,96	2,31			
35	10	0,99	1,29					
35	15	1,11	1,44	1,77	2,07			
35	20	1,22	1,60	1,96	2,31			
35	25	1,34	1,76	2,16	2,54			
40	10	1,11	1,44					
40	15	• 1,22	1,60	1,84	2,13			
40	20	• 1,34	1,76	2,16	2,54			
40	25	1,46	1,91	2,34	2,78			
40	30	1,58	2,07	2,55	3,01	3,83		
45	10	1,22	1,52					
45	15	1,34	1,76					
45	20	1,46	1,91	2,33	2,78			
45	25	1,58	2,07	2,42	3,01			
50	10	1,34	1,76					
50	15	1,46	1,92					
50	20	1,58	2,07		3,01			
50	25	1,77	2,23		3,25			
50	30	• 1,81	2,39		3,49	4,52	5,45	
50	40	2,05	2,70		3,96	5,15	6,28	7,35
60	10	1,58	2,07					
60	15	1,77	2,23					

• Anche zincato

TUBOLARE RETTANGOLARE

NERO | DECAPATO | ZINCATO

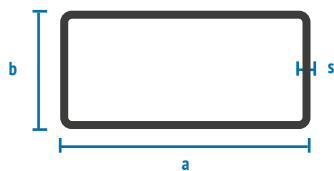

DIMENSIONI		SPESSORE mm							
a	b	1,5	2	3	4	5	6	8	10
mm		PESO kg							
60	20	1,81	2,39	3,30					
60	25	1,87	2,43	3,58					
60	30	• 1,99	2,59	3,77	4,83	6,28	7,36		
60	40	• 2,22	2,91	4,25	5,45	6,39	8,29	10,60	
60	50	2,46	3,22	4,66	5,98	8,02			
70	20	1,99	2,59	3,71					
70	25	2,10	2,75	3,95					
70	30	2,22	2,91	4,19	5,35				
70	35			4,25	5,45	7,07	8,29	10,60	
70	40	• 2,46	3,20	4,72	6,08	7,18	9,23	11,80	14,10
70	50	2,69	3,53	5,19	6,71	7,96	10,20	13,10	15,70
80	15	2,10	2,75						
80	20	2,22	2,91	4,19					
80	25	2,34	3,06	4,42					
80	30	2,46	3,33	4,56	5,98				
80	40	• 2,69	• 3,53	5,40	6,71	7,96	10,20	13,10	15,70
80	50	2,93	3,85	5,66	7,34	8,75	11,10	14,30	17,30
80	60	3,23	4,16	6,13	7,90	9,54	11,86	15,57	18,80
90	30	2,76	3,56	5,19	6,71				
90	40	2,99	3,85	5,60	7,24				
90	50	3,23	4,16	6,13	7,86	9,53	12,10	15,57	18,80
90	60		4,48	6,54	8,49	11,10	13,17		
100	20	2,76	3,57	6,13					
100	30	3,00	3,85	5,60	7,24				
100	40		4,16	6,13	7,90	9,54	12,10	15,57	18,80
100	50		• 4,48	6,60	8,59	10,32	13,00	16,83	20,40
100	60		4,79	7,07	9,11	11,10	12,98	18,09	22,00
100	80		5,42	8,01	10,38	13,91	15,44	20,40	25,10
110	50		4,79	7,02	9,12	11,11	13,90		
120	30		4,50	6,60	8,59				
120	40		4,52	7,70	9,22	11,11	13,90	18,10	22,00

• Anche zincato

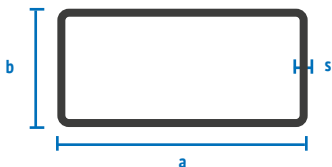

TUBOLARE RETTANGOLARE

NERO | DECAPATO | ZINCATO

DIMENSIONI		SPESSORE mm							
a	b	2	3	4	5	6	8	10	12
mm		PESO kg							
120	50	4,80	7,23	9,64	12,56	14,88	19,30	23,60	
120	60	5,41	8,01	10,48	12,67	15,44	20,40	25,10	
120	80	6,05	8,90	11,73	14,24	17,23	21,41	28,30	29,10
120	100		9,90	12,64	15,73	19,11	25,60	31,40	36,90
130	50	5,42	7,96	10,38	12,68	15,80			
140	40		7,66	10,22	12,70				
140	60	6,05	8,90	11,73	14,25	17,70	23,10	28,30	
140	70	6,36	9,37	12,27	15,04	18,70	24,40	29,80	34,40
140	80		9,84	12,99	15,83	19,60	25,60	31,40	36,40
150	30	5,52	8,19	10,80					
150	40	5,90	8,80	12,27	13,43				
150	50	6,05	8,90	11,73	14,25	17,70	23,10	28,30	
150	60			12,97	15,04				
150	75			13,60	16,20	20,10	27,00	32,00	
150	100		11,26	14,87	18,17	22,40	29,40	36,10	42,60
160	60		10,06	13,32	16,53	19,69			
160	80		10,79	14,14	17,38	21,50	28,10	34,50	40,70
160	90			15,20	18,17			36,10	42,60
160	100		11,96						
180	60		10,79	14,25	17,40	21,50	28,10	34,50	40,70
180	80		11,73	15,50	18,97	23,40	30,70	37,70	44,50
180	100			16,90	21,20	25,30	33,20	40,80	48,20
180	120			17,90	22,20	26,30	35,70	44,00	
180	140				23,73	28,14	38,20	47,10	
200	80		13,86	15,53	17,20	23,96	30,33	37,75	
200	100		13,62	18,01	22,09	26,19	35,70	44,00	52,00
200	120			19,30	23,83	29,06	38,20	47,10	55,80
200	150		16,02	21,15	26,10	30,87	42,00	51,80	61,40
220	80			17,90	22,16	26,60	34,12	41,53	
220	120			20,30	25,30	29,93	38,97	47,80	58,70
250	100		15,98	21,40	26,04	30,90	40,27	48,44	57,90
250	150			24,30	30,00	35,70	46,51	57,23	73,00
300	100			24,50	30,40	36,20	47,70	58,80	69,60
300	150			27,60	34,30	41,00	54,00	66,70	79,00

TUBOLARI PER SERRAMENTI

1A 1,72 kg/m (ANCHE ZINCATO)

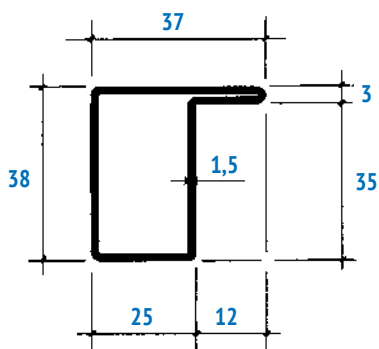

1B 2,10 kg/m (ANCHE ZINCATO)

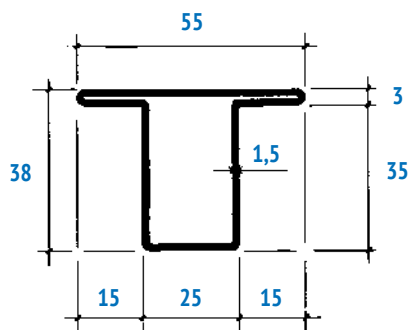

1C 1,99 kg/m (ANCHE ZINCATO)

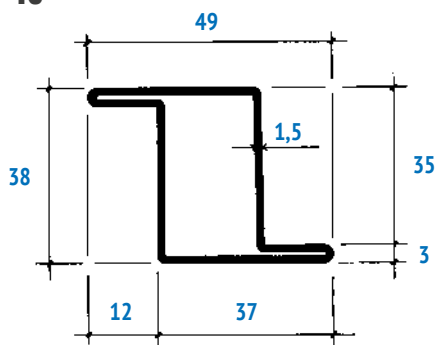

11A 1,34 kg/m (ANCHE ZINCATO)

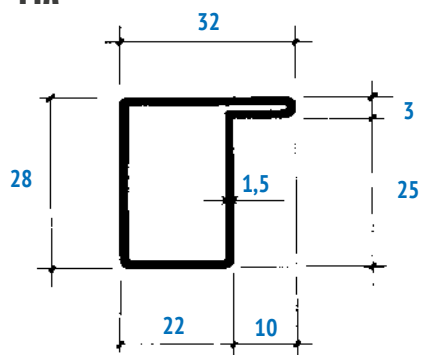

11B 1,57 kg/m (ANCHE ZINCATO)

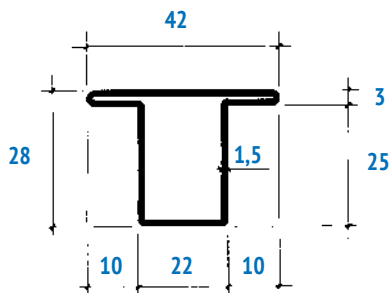

11C 1,57 kg/m (ANCHE ZINCATO)

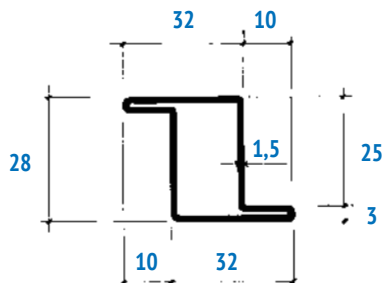

TUBOLARI PER SERRAMENTI

15A

2,04 kg/m

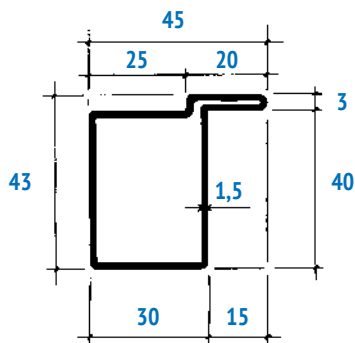

15T

2,45 kg/m

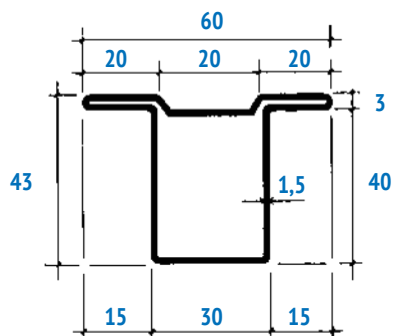

15Z

2,45 kg/m

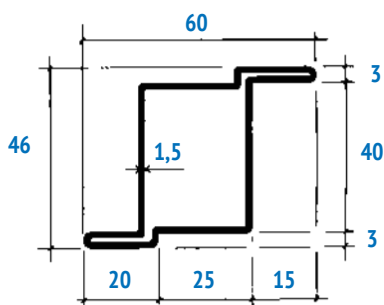

SF1/B

2,15 kg/m

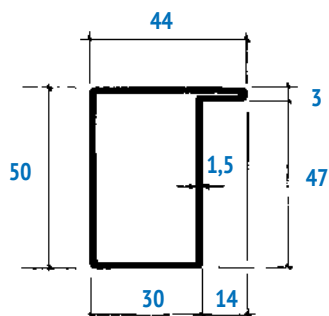

SF2/B

2,52 kg/m

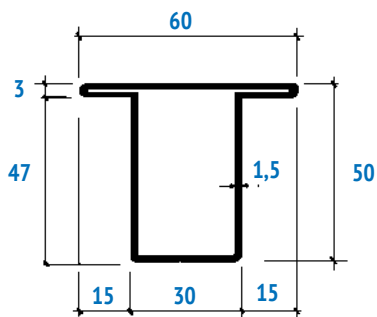

SF3/B

2,52 kg/m

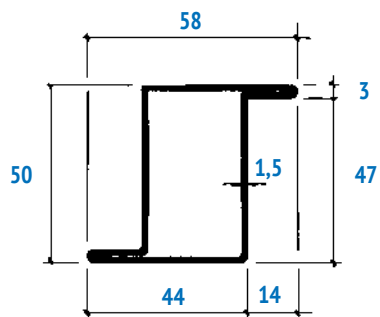

TUBOLARI PER SERRAMENTI

2A

1,76 kg/m

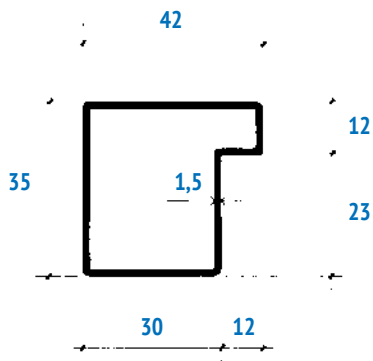

2B

1,88 kg/m

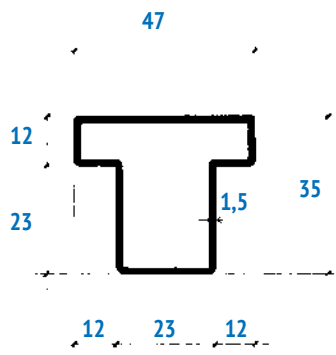

20L

3,30 kg/m

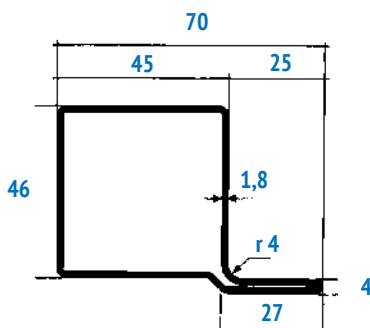

20T

4,10 kg/m

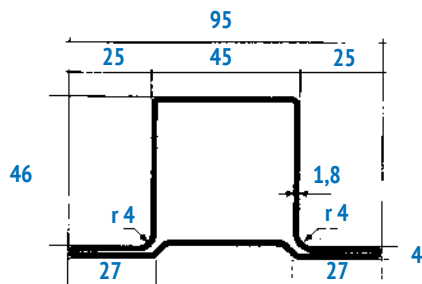

20Z

4,10 kg/m

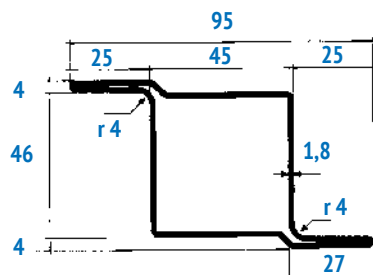

16A

2,33 kg/m

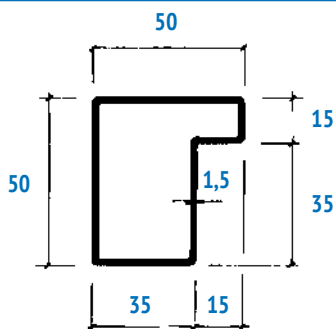
**16B**

2,33 kg/m

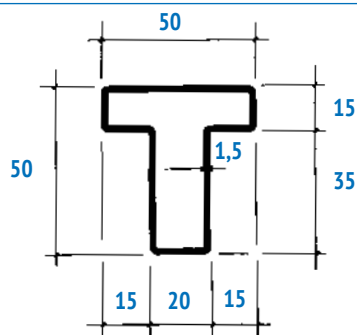
**40L**

2,50 kg/m

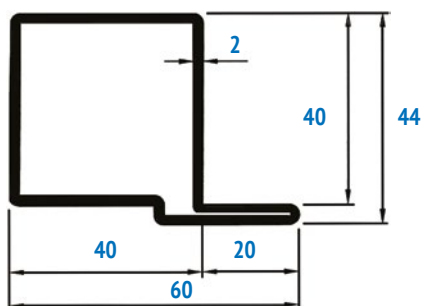
**16D**

4,65 kg/m

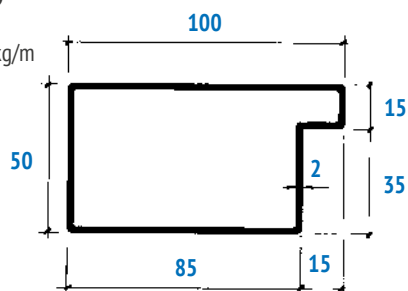
**21L**

2,05 kg/m

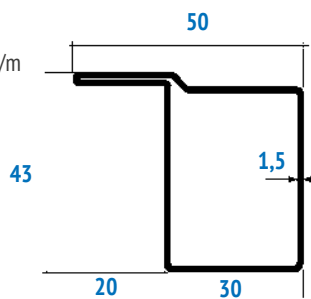
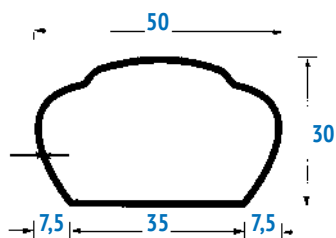
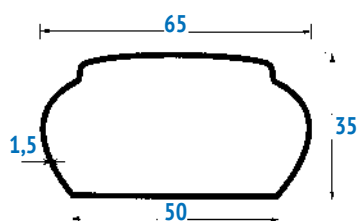
**MANCORRENTI****MT5** 1,65 kg/m**MT6** 2,15 kg/m

TUBOLARI SEZIONI SEMPLICI

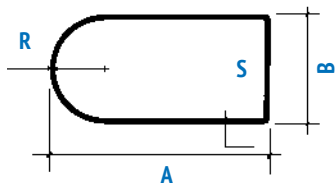

SEMIOVALE							
A	30	40	50	60	80	100	
B	15	20	25	30	40	50	
kg/m	15/10	1,05	1,35	1,66	1,97	2,67	3,47
per s.	20/10	1,38	1,78	2,17	2,61	3,55	5,54

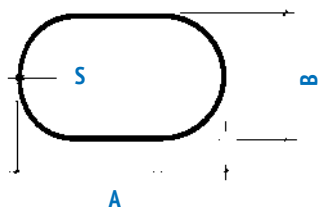

OVALE							
A	30	40	50	60	80	100	
B	15	20	25	30	40	50	
kg/m	15/10	0,98	1,24	1,55	1,87	2,48	3,00
per s.	20/10	1,28	1,63	1,95	2,47	3,30	3,45

PROFILO BATTIPIEDE

18 kg ALLA BARRA L = 6 m

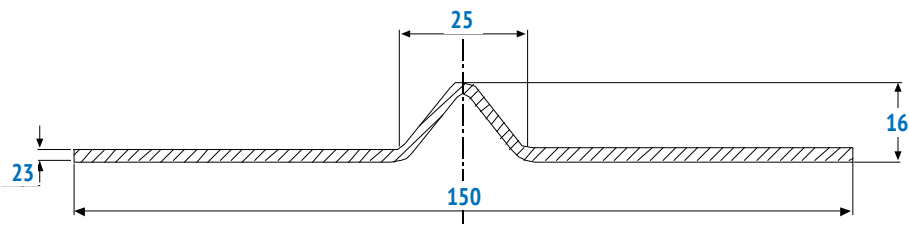

TUBO ACCIAIO INOX

AMPIA GAMMA DI PROFILATI TONDI, QUADRI E RETTANGOLARI

AISI 304 E 316L

SALDATURA METODO TIG E HF

LUNGHEZZA STANDARD 6 m

